



Part Number : [1204062001](#)

Product Description : Ultra-Lock 2.0 (M12) Receptacle, 4 Poles, Female (Straight), D-Coded, Back Panel Mount, M16 Mounting Threads, PCB Pins

Series Number : 120406

Status : Active

Product Category : Circular Industrial Connectors

Engineering Number : ERYD2U40000

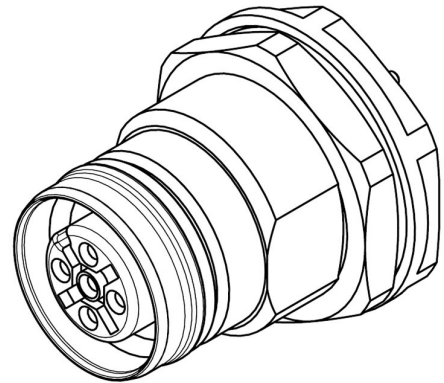

For illustration only. Pole size may deviate from image.

Documents & Resources

Drawings

[1204062001_sd.pdf](#)

Specifications

[1204000001-P10.pdf](#)

Product Environment Compliance

Compliance

China RoHS	Not Reviewed
EU ELV	Not Reviewed
Low-Halogen Status	Not Reviewed
REACH SVHC	Not Reviewed
EU RoHS	Not Reviewed

Multiple Part Product Compliance Statements

- Eu RoHS
- REACH SVHC
- Low-Halogen

Multiple Part Industry Compliance Documents

- IPC 1752A Class C
- IPC 1752A Class D
- Molex Product Compliance Declaration
- IEC-62474

Part Details

General

Status	Active
Category	Circular Industrial Connectors
Series	120406
Description	Ultra-Lock 2.0 (M12) Receptacle, 4 Poles, Female (Straight), D-Coded, Back Panel Mount, M16 Mounting Threads, PCB Pins
IP Rating	IP67, IP69K
Product Name	Ultra-Lock 2.0 (M12)
Type	PCB Mount
UPC	195842274938

Electrical

Current - Maximum per Contact	4.0A
Voltage - Maximum	250V

Physical

Coupling Type	Internal Thread Push to Lock
Gender	Female
Keyway	D-Coded
Length	N/A
Material - Component	Nickel-plated Brass
Mounting Thread Size	M16
Orientation	Straight
Panel Mount	Back
Poles	4
Temperature Range - Operating	-40° to +85°C
Wire/Cable Type	UL 1569
Wire Size (AWG)	N/A

This document was generated on Mar 27, 2025