



**Part Number :** [1300130093](#)

**Product Description :** Mini-Change A-Size Receptacle, 2 Poles, Female (Straight) to 16 AWG Leads, 0.305m (1.0') Length with Mounting Flange

**Series Number :** 130013

**Status :** Active

**Product Category :** Circular Industrial Connectors

**Engineering Number :** 1R2G04A20A120

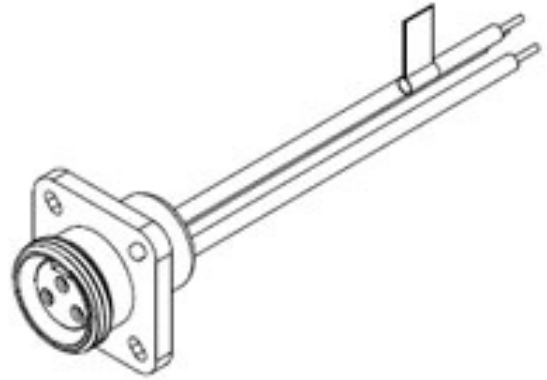

---

## Documents & Resources

### Drawings

[1300130093\\_sd.pdf](#)

---

## Product Environment Compliance

### Compliance

GADSL/IMDS	Not Relevant
China RoHS	Not Relevant
EU ELV	Compliant with Exemption 10(a) per 2000/53/EC
Low-Halogen Status	Not Relevant
REACH SVHC	Contains Lead per D(2023)3788-DC (14 Jun 2023)
EU RoHS	Compliant with Exemption 6(c) per EU 2015/863

### Multiple Part Product Compliance Statements

- Eu RoHS
- REACH SVHC
- Low-Halogen

### Multiple Part Industry Compliance Documents

- IPC 1752A Class C
- IPC 1752A Class D
- Molex Product Compliance Declaration
- IEC-62474

## Part Details

### General

Status	Active
Category	Circular Industrial Connectors
Series	130013
Description	Mini-Change A-Size Receptacle, 2 Poles, Female (Straight) to 16 AWG Leads, 0.305m (1.0') Length with Mounting Flange
IP Rating	IP67
NEMA Rating	NEMA 6
Product Name	Mini-Change
Type	Single Ended (pigtail)
UPC	78678843878

### Agency

CSA	LR6837
UL	E152210

### Electrical

Current - Maximum per Contact	13.0A
Voltage - Maximum	600V AC/DC

### Physical

Coupling Type	External Thread
Gender	Female
Keyway	Single
Length	0.305m
Material - Component	Gray Anodized Aluminum
Mounting Thread Size	N/A
Orientation	Straight
Panel Mount	Front
Poles	2

Temperature Range - Operating	-20° to +105°C
Wire/Cable Type	E152210
Wire Size (AWG)	16

---

This document was generated on Mar 27, 2025