



Part Number : [1300130201](#)

Product Description : Mini-Change A-Size Receptacle with Leads, 1/2" - 14 NPT Threads, Male (Straight) to Leads, 3 Poles, 0.20m (7.87") Length

Series Number : 130013

Status : Active

Product Category : Circular Industrial Connectors

Engineering Number : 1R3006A20A060

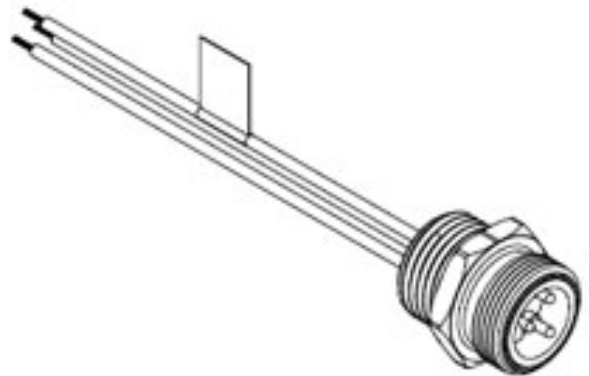

Documents & Resources

Drawings

[1300130201_sd.pdf](#)

Product Environment Compliance

Compliance

GADSL/IMDS	Not Relevant
China RoHS	
EU ELV	Not Relevant
Low-Halogen Status	Not Low-Halogen per IEC 61249-2-21
REACH SVHC	Contains Di-(2-ethylhexyl)phthalat; Lead; Terphenyl, hydrogenated per D(2023)8585-DC (23 Jan 2024)
EU RoHS	Not Compliant per EU 2015/863

Multiple Part Product Compliance Statements

- Eu RoHS
- REACH SVHC
- Low-Halogen

Multiple Part Industry Compliance Documents

- IPC 1752A Class C
- IPC 1752A Class D
- Molex Product Compliance Declaration
- IEC-62474

Part Details

General

Status	Active
Category	Circular Industrial Connectors
Series	130013
Description	Mini-Change A-Size Receptacle with Leads, 1/2" - 14 NPT Threads, Male (Straight) to Leads, 3 Poles, 0.20m (7.87") Length
IP Rating	IP67
NEMA Rating	NEMA 6
Product Name	Mini-Change
Type	Single Ended (pigtail)
UPC	78678842874

Agency

CSA	LR6837
UL	E152210

Electrical

Current - Maximum per Contact	13.0A
Voltage - Maximum	600V AC/DC

Physical

Coupling Type	External Thread
Gender	Male
Keyway	Single
Length	0.20m
Material - Component	Zinc Die-Cast with Black Epoxy
Mounting Thread Size	1/2" - 14 NPT
Orientation	Straight
Panel Mount	N/A
Poles	3

Temperature Range - Operating	-20° to +105°C
Wire/Cable Type	N/A
Wire Size (AWG)	16

This document was generated on Mar 27, 2025