



Part Number : [1300130203](#)

Product Description : Mini-Change A-Size Receptacle, 3 Poles, 1/2" - 14 NPT Threads, Passivated Stainless Steel, Male (Straight) to 16 AWG Leads, 0.305 (1.0') Length

Series Number : 130013

Status : Active

Product Category : Circular Industrial Connectors

Engineering Number : 1R3006A20A1201

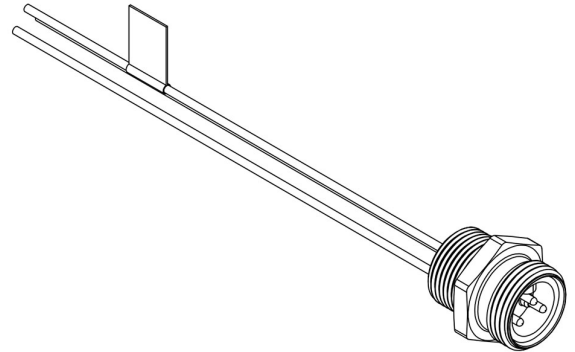

---

## Documents & Resources

### Drawings

[1300130203\\_sd.pdf](#)

---

## Product Environment Compliance

### Compliance

GADSL/IMDS	Not Relevant
China RoHS	
EU ELV	Not Relevant
Low-Halogen Status	Not Low-Halogen per IEC 61249-2-21
REACH SVHC	Contains Lead per D(2024)4144-DC (27 June 2024)
EU RoHS	Compliant with Exemption 6(c) per EU 2015/863

### Multiple Part Product Compliance Statements

- Eu RoHS
- REACH SVHC
- Low-Halogen

### Multiple Part Industry Compliance Documents

- IPC 1752A Class C
- IPC 1752A Class D
- Molex Product Compliance Declaration

- IEC-62474

- chemSHERPA (xml)

EU RoHS Certificate of Compliance

---

## Part Details

### General

Status	Active
Category	Circular Industrial Connectors
Series	130013
Description	Mini-Change A-Size Receptacle, 3 Poles, 1/2" - 14 NPT Threads, Passivated Stainless Steel, Male (Straight) to 16 AWG Leads, 0.305 (1.0') Length
IP Rating	IP67
NEMA Rating	NEMA 6
Product Name	Mini-Change
Type	Single Ended (pigtail)
UPC	78678838619

### Agency

CSA	LR6837
UL	E152210

### Electrical

Current - Maximum per Contact	13.0A
Voltage - Maximum	600V AC/DC

### Physical

Coupling Type	External Thread
Gender	Male
Keyway	Single
Length	0.305m
Material - Component	Stainless Steel
Mounting Thread Size	1/2" - 14 NPT
Net Weight	56.699/g

Orientation	Straight
Panel Mount	Front
Poles	3
Temperature Range - Operating	-20° to +90°C
Wire/Cable Type	UL 1015
Wire Size (AWG)	16

---

---

This document was generated on Mar 27, 2025