



Part Number : [1300340008](#)

Product Description : Micro-Change (M12)
Drop Connector, Threaded, Single Keyway,
Straight Male 5 Poles

Series Number : 130034

Status : Active

Product Category : Circular Industrial
Connectors

Engineering Number : 8A5006-32DN

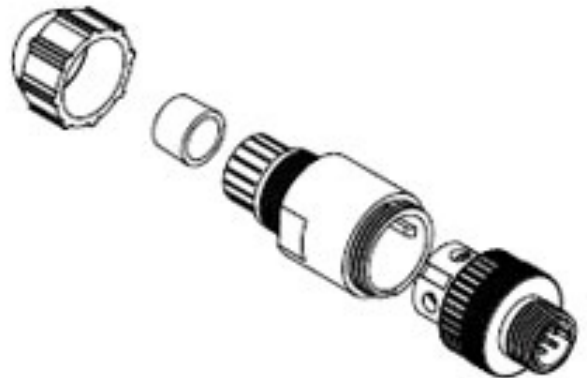

Documents & Resources

Drawings

[1300340008_sd.pdf](#)

Product Environment Compliance

Compliance

GADSL/IMDS	Not Relevant
China RoHS	
EU ELV	Not Relevant
Low-Halogen Status	Not Low-Halogen per IEC 61249-2-21
REACH SVHC	Contains Lead per D(2024)7663-DC (21 Jan 2025)
EU RoHS	Compliant with Exemption 6(c) per EU 2015/863

Multiple Part Product Compliance Statements

- Eu RoHS
- REACH SVHC
- Low-Halogen

Multiple Part Industry Compliance Documents

- IPC 1752A Class C
- IPC 1752A Class D
- Molex Product Compliance Declaration
- IEC-62474

Part Details

General

Status	Active
Category	Circular Industrial Connectors
Series	130034
Description	Micro-Change (M12) Drop Connector, Threaded, Single Keyway, Straight Male 5 Poles
Approvals	cCSAus certified
IP Rating	IP67
Product Name	Micro-Change (M12)
Type	Field Attachable Connector
UPC	78678848876

Agency

CSA	LR6837
-----	--------

Electrical

Current - Maximum per Contact	4.0A
Voltage - Maximum	36V

Physical

Cable Diameter	4.06-8.13mm (.160-.320")
Coupling Type	External Thread
Diagnostics / LEDs	No
Diagnostics Port	No
Gender	Male
Keyway	Single
Material - Connector Body	Polyamide
Material - Contact	Copper Alloy
Material - Coupling Nut	Nickel-plated Brass
Material - Plating Mating	n/a

Net Weight	9.540/g
Orientation	Straight
Poles	5
Temperature Range - Operating	-25°C to +90°C
Wire Size (AWG)	N/A

This document was generated on Mar 27, 2025