



Part Number : [1300660154](#)

Product Description : BradPower D-Size (1 3/8"-M35) Female, 1/2" NPT 2, 4 Poles, Receptacle, Female (Straight) to 10 AWG Leads, 1.0m (3.28') Length

Series Number : 130066

Status : Active

Product Category : Circular Industrial Connectors

Engineering Number : CR4000A30M010

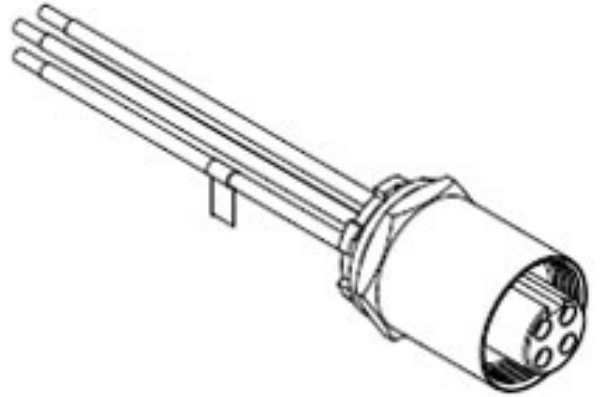

Documents & Resources

Drawings

[1300660154_sd.pdf](#)

Product Environment Compliance

Compliance

GADSL/IMDS	Not Relevant
China RoHS	
EU ELV	Not Relevant
Low-Halogen Status	Not Reviewed per IEC 61249-2-21
REACH SVHC	Not Reviewed per D(2024)7663-DC (21 Jan 2025)
EU RoHS	Compliant with Exemption 6(c) per EU 2015/863

Multiple Part Product Compliance Statements

- Eu RoHS
- REACH SVHC
- Low-Halogen

Multiple Part Industry Compliance Documents

- IPC 1752A Class C
- IPC 1752A Class D
- Molex Product Compliance Declaration
- IEC-62474
- chemSHERPA (xml)

Part Details

General

Status	Active
Category	Circular Industrial Connectors
Series	130066
Description	BradPower D-Size (1 3/8"-M35) Female, 1/2" NPT 2, 4 Poles, Receptacle, Female (Straight) to 10 AWG Leads, 1.0m (3.28') Length
IP Rating	IP67
Product Name	BradPower D-Size
Type	Single Ended (pigtail)
UPC	78678856307

Agency

UL	E258922
----	---------

Electrical

Current - Maximum per Contact	25.0A
Voltage - Maximum	600V

Physical

Coupling Type	Internal Thread
Gender	Female
Keyway	Single
Length	1.0m
Material - Component	Black Anodized Aluminum
Mounting Thread Size	1/2" NPT
Orientation	Straight
Panel Mount	Back, Front
Poles	4
Temperature Range - Operating	0° to +105°C
Wire/Cable Type	N/A
Wire Size (AWG)	10

This document was generated on Mar 27, 2025