



Part Number : [1300680075](#)

Product Description : BradPower D-Size (1 3/8"-M35) 4-Pole Reducing Tee, with 4-Pole BradPower A-Size (7/8"-M22) Drop Cable, Length 1.0m Cable, 14 AWG

Series Number : 130068

Status : Active

Product Category : Industrial Tees and Splitters

Engineering Number : TC40200A46M010

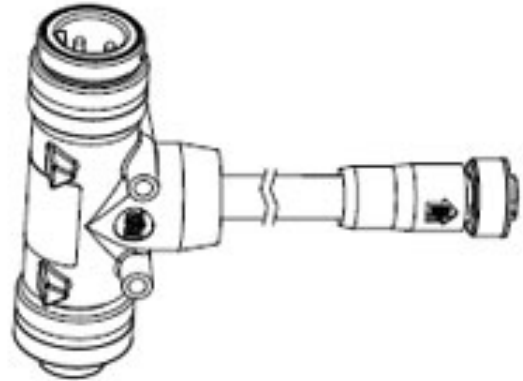

Documents & Resources

Drawings

[1300680075_sd.pdf](#)

Product Environment Compliance

Compliance

China RoHS	Not Reviewed
EU ELV	Not Reviewed
Low-Halogen Status	Not Reviewed
REACH SVHC	Not Reviewed
EU RoHS	Not Reviewed

Multiple Part Product Compliance Statements

- Eu RoHS
- REACH SVHC
- Low-Halogen

Multiple Part Industry Compliance Documents

- IPC 1752A Class C
- IPC 1752A Class D
- Molex Product Compliance Declaration
- IEC-62474
- chemSHERPA (xml)

EU RoHS Certificate of Compliance

Part Details

General

Status	Active
Category	Industrial Tees and Splitters
Series	130068
Description	BradPower D-Size (1 3/8"-M35) 4-Pole Reducing Tee, with 4-Pole BradPower A-Size (7/8"-M22) Drop Cable, Length 1.0m Cable, 14 AWG
IP Rating	IP67
Product Name	BradPower D-Size
Type	Power Tap Tee
UPC	78678898113

Agency

UL	E258922
----	---------

Electrical

Current - Maximum per Contact	15.0A, 25.0A
Voltage - Maximum	600V AC/DC

Physical

Color - Cable Jacket	Gray
Drop Connector	BradPowerA-Size (7/8"-M22)
Drop Gender	Female
Keyway	Single
Left Trunk Connector	BradPower D-Size (1 3/8"-M35)
Left Trunk Gender	Female
Leg 1 Length	N/A
Leg 2 Length	N/A
Material - Cable Jacket	PVC
Material - Connector Body	PVC
Material - Coupling Nut	Anodized Aluminum
Poles	4
Right Trunk Connector	BradPower D-Size (1 3/8"-M35)

Right Trunk Gender	Male
Temperature Range - Operating	-20°C to +90°C

This document was generated on Mar 27, 2025