

| LENGTH OF THE ASSEMBLIES | QTY. OF SINGLE BAGS PACKED IN ONE CARTON BOX | CARTON BOX |
|--------------------------|--|------------|
| 0.5M CABLE ASSEMBLY      | 24 CORDSETS                                  | 967070001  |
| 1.0M CABLE ASSEMBLY      | 24 CORDSETS                                  | 967080005  |
| 2.0M CABLE ASSEMBLY      | 24 CORDSETS                                  | 967080005  |
| 3.0M CABLE ASSEMBLY      | 12 CORDSETS                                  | 967080005  |
| 5.0M CABLE ASSEMBLY      | 12 CORDSETS                                  | 967080005  |
| 10.0M CABLE ASSEMBLY     | 8 CORDSETS                                   | 859989061  |
| 15.0M CABLE ASSEMBLY     | 8 CORDSETS                                   | 859989061  |
| 20.0M CABLE ASSEMBLY     | 4 CORDSETS                                   | 967080005  |
| 25.0M CABLE ASSEMBLY     | 4 CORDSETS                                   | 967080005  |
| 30.0M CABLE ASSEMBLY     | 2 CORDSETS                                   | 967080005  |
| 35.0M CABLE ASSEMBLY     | 2 CORDSETS                                   | 967080005  |
| 40.0M CABLE ASSEMBLY     | 2 CORDSETS                                   | 967080005  |
| 45.0M CABLE ASSEMBLY     | 2 CORDSETS                                   | 967080005  |

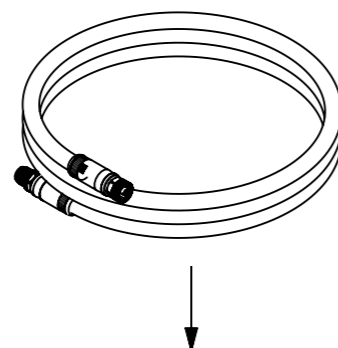

EACH CABLE SINGLE PACKED INTO A POLY BAG

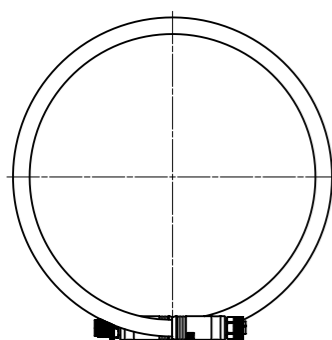
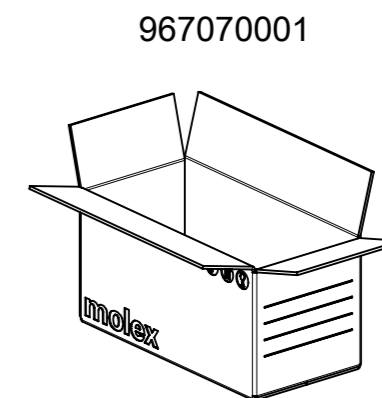
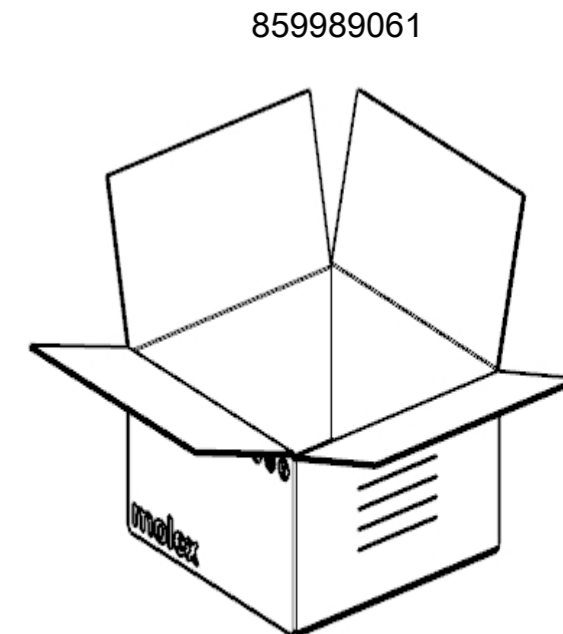
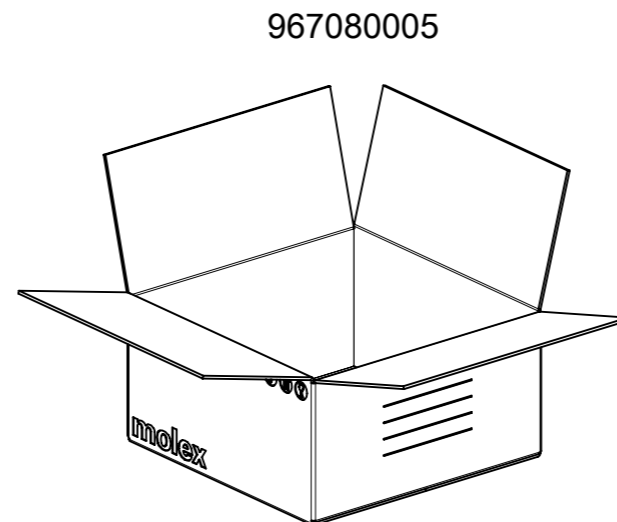
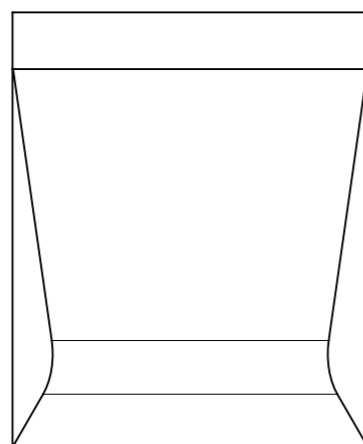

TWO STRING PER CORDSET  
NOT FOR LENGTH SHORTER 1 m  
(POSITION NOT DEFINED)

NOTES:

1. PACK EACH ASSEMBLY INDIVIDUALLY IN ONE SUITABLE POLY BAG.
2. NO FILLING MATERIAL ALLOWED
3. WRAP THE CARTON BOXES WITH ADHESIVE TAPE AROUND 360° IN TWO PLANES
4. PACKAGING PERFORMED DURING THE PRODUCT VALIDATION THE DROP TEST ACC. ES-40000-7001
5. THE PARTS SHALL BE PACKED TO BE PROTECTED AGAINST DAMAGE DURING HANDLING, TRANSIT AND STORAGE

|  |   |                        |  |        |              |  |  |  |
|--|---|------------------------|--|--------|--------------|--|--|--|
| FUNCTIONAL SYMBOLS                                   | THIS DRAWING CONTAINS INFORMATION THAT IS PROPRIETARY TO MOLEX ELECTRONIC TECHNOLOGIES, LLC AND SHOULD NOT BE USED WITHOUT WRITTEN PERMISSION |                        |  |        |              |  |  |  |
|  | DIMENSION UNITS   | SCALE                  |  |        |              | CURRENT REV DESC: CHANGED CARTON BOX FROM 967080005 TO 859989061 FOR 10M AND 15M |  |  |
| $\nabla_A = 0$                                       | mm  | 1:5                    | EC NO: 811062<br>DRWN: RSCHIEBER 2025/01/28<br>CHK'D: RSILLER 2025/01/29<br>APPR: RSILLER 2025/01/29<br>INITIAL REVISION:<br>DRWN: NFRITZEN 2020/03/30<br>APPR: RSILLER 2021/03/17 |        |              |  |  |  |
| $\nabla_E = 0$                                       | GENERAL TOLERANCES (UNLESS SPECIFIED)   |                        |  |        |              | PACKAGING M12 5P L-CODE  |  |  |
| $\nabla_F = 0$                                       | ANGULAR TOL $\pm 0.5^\circ$   |                        |  |        |              | PACKAGING DESIGN DRAWING   |  |  |
| DIVISIONAL SYMBOLS                                   | 4 PLACES  | $\pm$                  |  |        |              | DOCUMENT NUMBER  |  |  |
|  | 3 PLACES  | $\pm$                  |  |        |              | DOC TYPE DOC PART REVISION   |  |  |
|  | 2 PLACES  | $\pm 0.05$             | 1205010169 PDD K00 A2  |        |              |  |  |  |
|  | 1 PLACE   | $\pm 0.1$              | MATERIAL NUMBER CUSTOMER SHEET NUMBER  |        |              |  |  |  |
|  | 0 PLACES  | $\pm 0.15$             | SEE TABLE GENERAL MARKET 1 OF 1  |        |              |  |  |  |
| DRAFT WHERE APPLICABLE MUST REMAIN WITHIN DIMENSIONS |   | THIRD ANGLE PROJECTION | DRAWING  | SERIES | SHEET NUMBER |  |  |  |
|  |   |                        | A3-SIZE  | 120501 | 1 OF 1       |  |  |  |