

NOTES:

- 1. ASSEMBLIES ARE TO BE PACKED 10 PER PACKING SLEEVE (D)
- 2. EACH BOX IS TO BE PACKED WITH 54 PACKING SLEEVES
- 3. FILLED BOX IS TO BE PACKED IN SUCH A MANNER THAT WILL PREVENT SHIFTING OR DAMAGE TO PACKING SLEEVE OR PARTS CONTAINED WITHIN PACKING SLEEVE. BUBBLE WRAP OR SIMILAR IS ACCEPTABLE
- 4. LABEL IS TO BE PRINTED WITH CUSTOMER P/N, MOLEX P/N, DATE CODE AND ELECTRICAL SPECS. ATTACH LABEL AS SHOWN
- 5. RETENTION PINS MUST BE FULLY ENGAGED INTO THE SLEEVE IN ORDER TO LOCK THEM INTO POSITION.
- 6. EST. WEIGHT OF FULLY LOADED BOX: 37 LBS.

NOTAS:

- 1. LOS MONTAJES DEBEN SER EMBALADOS 10 POR LA MANGA DEL EMBALAJE (D)
- 2. CADA CAJA DEBE SER EMBALADA CON 54 MANGAS QUE EMBALAN
- 3. LA CAJA LLENADA ESTÁ A EMBALADO ADENTRO POR EJEMPLO LA MANERA QUE EVITARÁ EL DESPLAZAMIENTO O EL DAÑO A LA MANGA DEL EMBALAJE O PARTE CONTAINED DENTRO DE LA MANGA DEL EMBALAJE. EL ABRIGO DE BURBUJA O SIMILAR ES ACEPTABLE
- 4. LA ETIQUETA DEBE SER IMPRESA CON EL CLIENTE P/N, MOLEX P/N, CÓDIGO DE LA FECHA Y ESPEC. ELÉCTRICAS. SUJETE LA ETIQUETA COMO SE MUESTRA
- 5. LOS PASADOR DE RETENCIÓN SE DEBEN DEDICAR COMPLETAMENTE EN LA MANGA PARA TRABARLOS EN LA POSICIÓN
- 6. EST. PESO DE LA CAJA COMPLETAMENTE CARGADA: 37 LIBRAS.

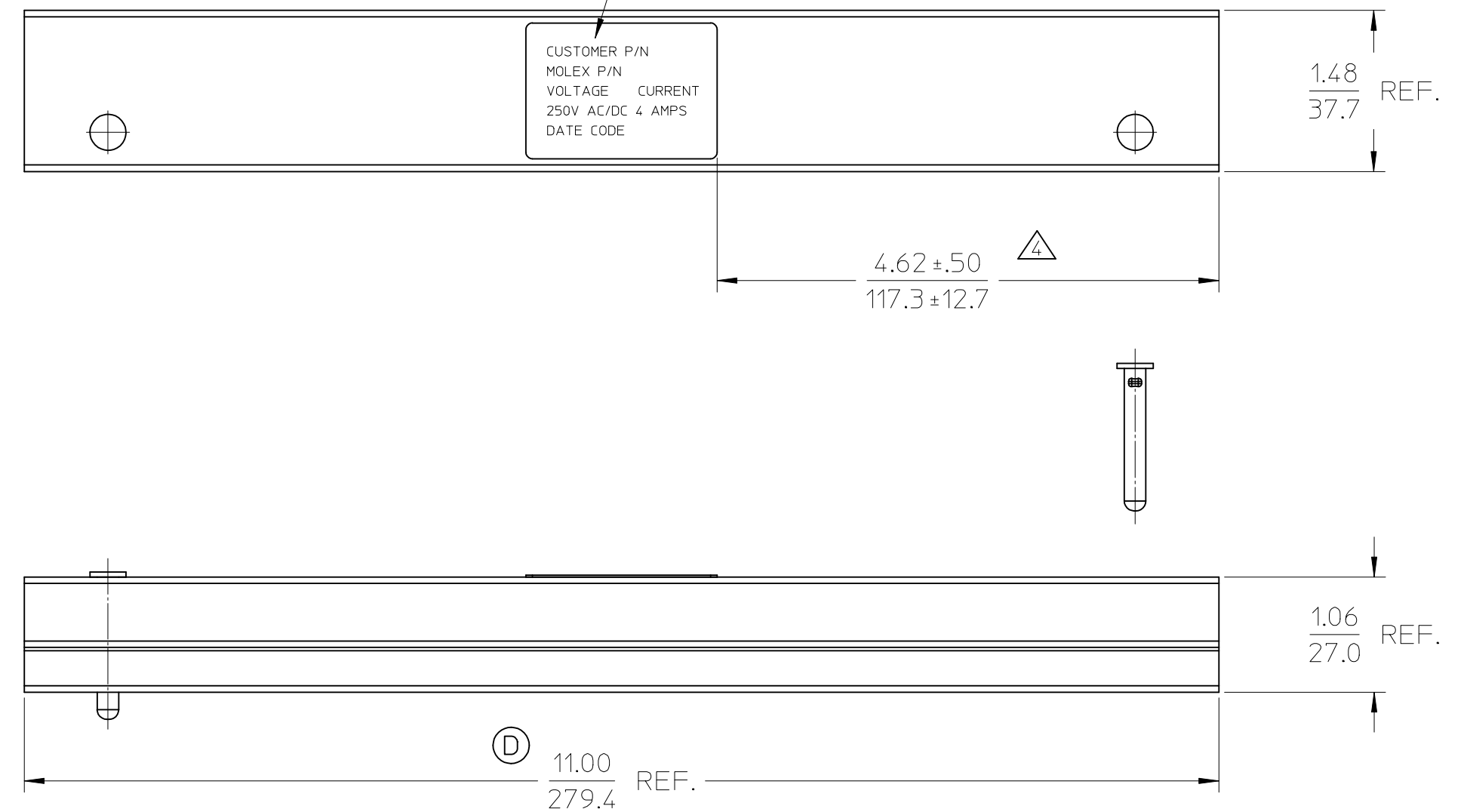
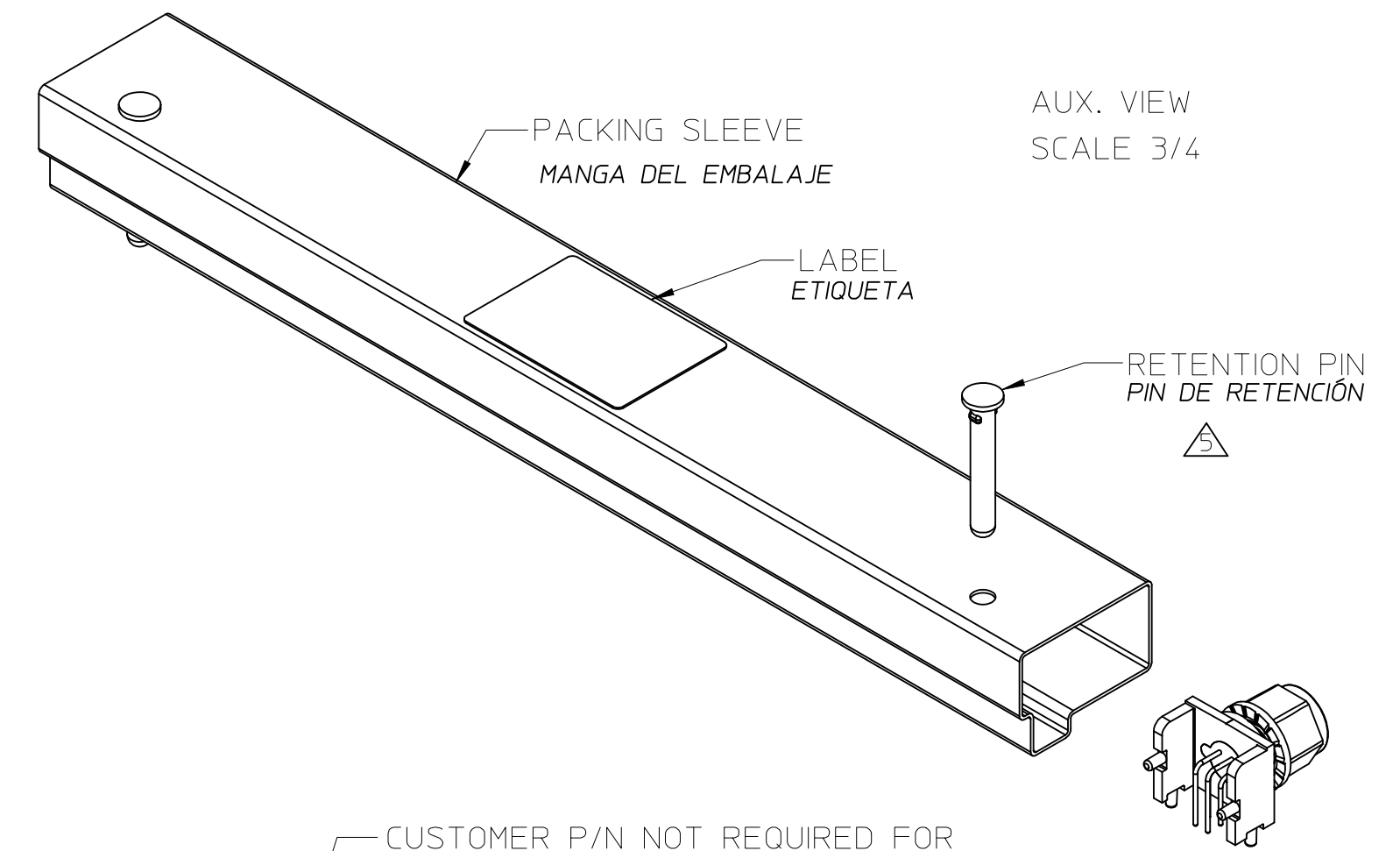

RECEPTACLE ASSEMBLY
REF. 4/C 90 DEG SHOWN
REFERENCIA DEL MONTAJE DEL RECEPTÁCULO.
4/C 90 GRADOS DEMOSTRADOS

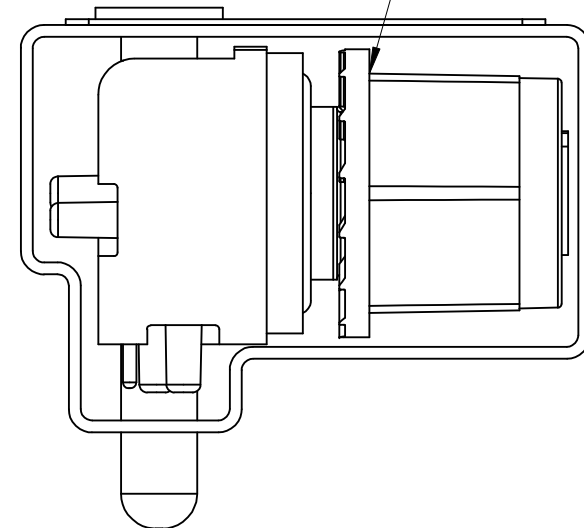

END VIEW
SCALE: 2X

OAL WAS 11.44, QTY. WAS 11 EC NO: WNA2011-0521 DRWN: RSTONE 2011/04/27 CHKD: K. JOZWIK 2011/04/29 APPR: J. MURPHY 2011/08/13	QUALITY SYMBOLS ▽=0 ◻=0	GENERAL TOLERANCES (UNLESS SPECIFIED)		DIMENSION STYLE IN/MM		SCALE 1:1.33	DESIGN UNITS INCH	THIRD ANGLE PROJECTION		
		4 PLACES	± ---	± ---	DRAWN BY RSTONE	DATE 2010/10/15	TITLE PACKING SPECIFICATION FOR MIC PCB MOUNT RECEPTACLE ASSEMBLY			
		3 PLACES	± ---	± ---	CHECKED BY K. JOZWIK	DATE 2010/10/21				
		2 PLACES	± ---	± ---	APPROVED BY	DATE	molex MOLEX INCORPORATED			
1 PLACE	± ---	± ---	ANGULAR ± 2 °		MATERIAL NO.	DOCUMENT NO. PK-130299-001	SHEET NO. 1 OF 1			
DRAFT WHERE APPLICABLE MUST REMAIN WITHIN DIMENSIONS		THIS DRAWING CONTAINS INFORMATION THAT IS PROPRIETARY TO MOLEX INCORPORATED AND SHOULD NOT BE USED WITHOUT WRITTEN PERMISSION								